

FIG. 1145

PTFE WAFER BUTTERFLY VALVE



Lloyd's Register

PED 97/23/CE



- Size :** DN 32/40 to 300 mm
Ends : Between flanges ISO PN10/16 and ANSI150
Min Temperature : - 25°C
Max Temperature : + 200°C
Max Pressure : 16 Bars up to DN150
Specifications : Long neck for isolation
Wafer type
2 parts body
ISO 5211 mounting pad
- Materials :** Ductile iron EN GJS 500-7 body

SPECIFICATIONS :

- Long neck for isolation
- ISO 5211 mounting pad
- Wafer type
- Between flanges ISO PN10/16 from DN32/40 to 300 and ISO PN20 ANSI150 from DN40 to 300
- 2 parts body
- Full crossing stem
- PTFE sealing ring 3 mm thickness with silicone elastic gasket 6 mm thickness
- Stainless steel disc
- 9 positions lever with locking device up to DN200
- Rilsan coated body color RAL 5024 , 250-300 microns thickness
- Stem extension 75 mm length (option)
- Square lever 30x30 mm for special key (option)

USE :

- For corrosive fluids (acids ...)
- Min and max Temperature Ts : - 25°C to + 200°C
- Max Pressure PN : 16 bars up to DN150, 10 bars over (see graph under)

RANGE :

- With lever from DN 32/40 to DN 200
- With IP65 gear box from DN 250 to DN 300 (possible from DN 32/40 to DN200 : **Ref. 1197**)
- On request , IP65 chain gear box (**Ref. 1194**) from DN 32/40 to DN 300
- On request , stem extension with special length (**Ref. 98665**)
- On request, stainless steel lever and bolting (**Ref. 9831250-9831264**)

PRESSURE / TEMPERATURE GRAPH (STEAM EXCLUDED) :

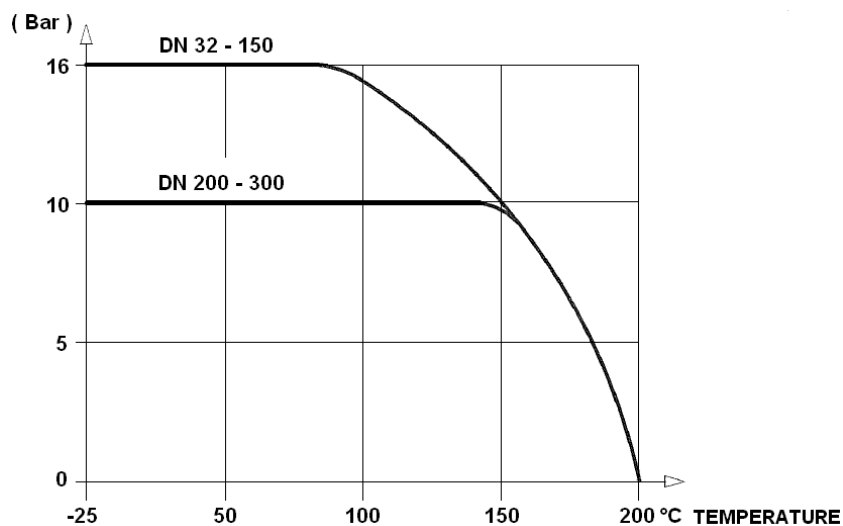

ENDS :

- Between flanges ISO PN10/16 from DN32/40 to 300 and ISO PN20 ANSI150 from DN40 to 300

TORQUE VALUES (in Nm with safety coefficient of 30 % included) at 10 Bars :

DN	32/40	50	65	80	100	125	150	200	250	300
Torque (Nm)	25	40	45	75	90	160	180	230	475	680

FLOW COEFFICIENT Kvs (m3 / h) :

DN	32/40	50	65	80	100	125	150	200	250	300
Kvs (m3/h)	70	109	200	334	551	901	1427	2383	3825	5659

HEAD LOSS GRAPH :

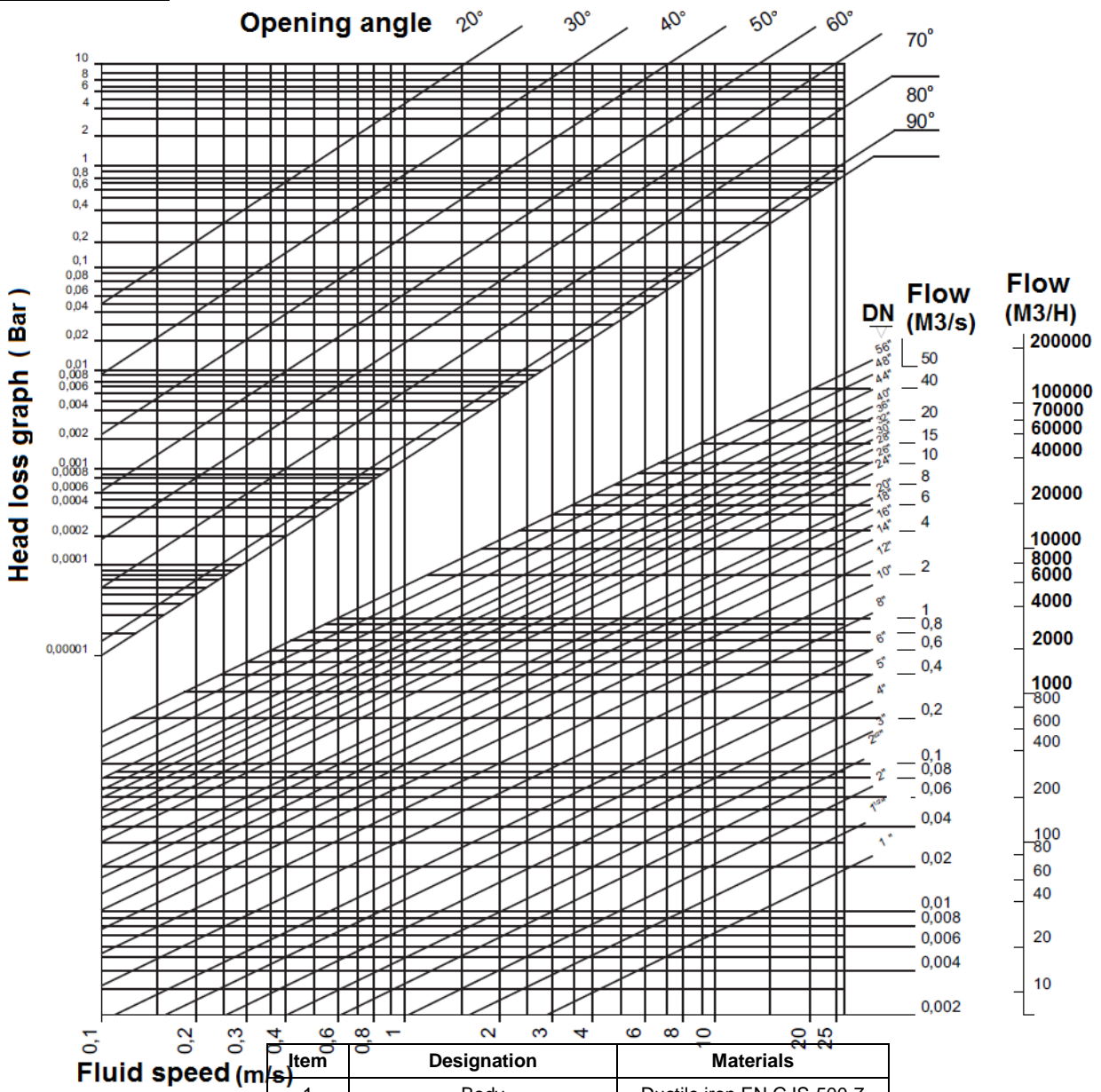

Item	Designation	Materials
1	Body	Ductile iron EN GJS-500-7
2	Disc	ASTM A351 CF8M
3	Elastic ring	PTFE
4	Stem	SS 316
5	Insert	Silicone
6	Plate	Aluminium
7	Circlips	SS 316
8	Ring	SS 316
9	Socket	SS 316
10	O ring	FKM
11	O ring	FKM
12	Washer	SS 316
13	Plate screw	A4
14	O ring	FKM
15	Body screw	A4
	Lever	Aluminium

MATERIALS :

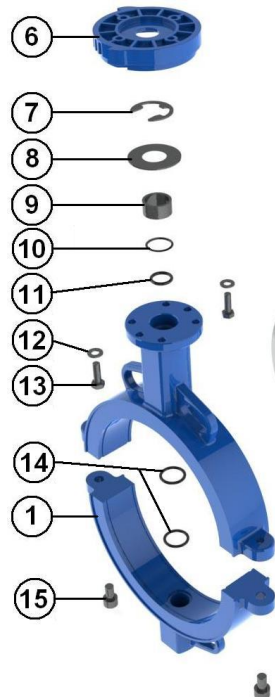

SIZE ISO PN10 (in mm) :

• **Valves :**

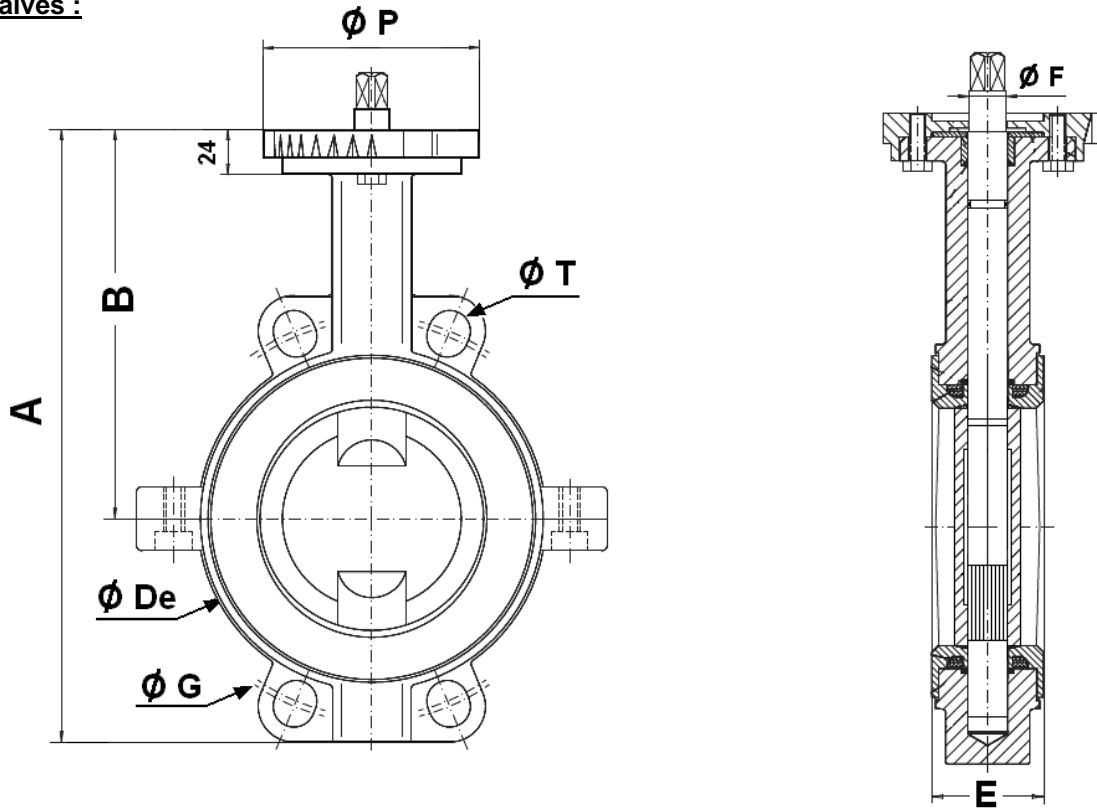

DN	32/40	50	65	80	100	125	150	200	250	300
A	205	228	243	266	294	324	349	438	448	515
B	140	156	162	170	185	207	216	256	248	280
Ø De	83	102	119	135	155	185	208	270	320	373
E	33	43	46	46	52	56	56	60	68	78
Ø F	10.5	10.5	14.5	16.5	16.5	18.5	18.5	22.5	25.5	30.5
Ø G	110	125	145	160	180	210	240	295	350	400
Ø P	88	88	88	88	88	105	105	105	150	150
Ø T	18	18	18	18	18	18	23	23	23	23
Weight (Kg)	2.5	4	4.57	5.18	6.5	9.5	10.37	16.8	31	42

• **Levers :**

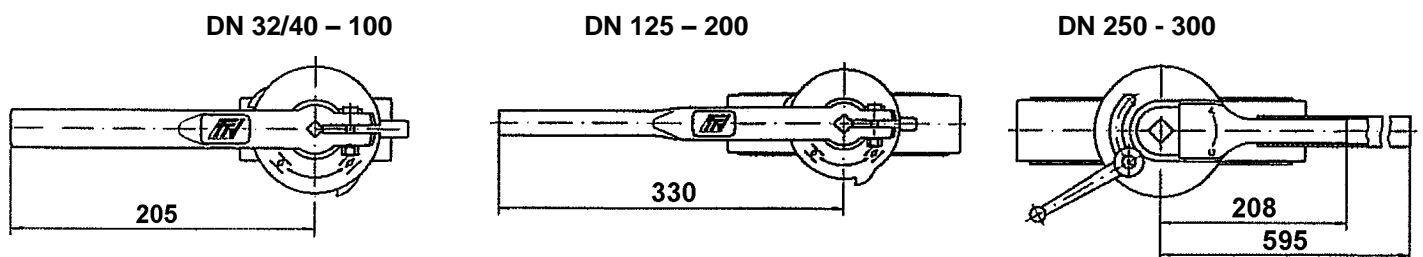

SIZE ISO PN10 (in mm) :

- **Valves with gear box :**

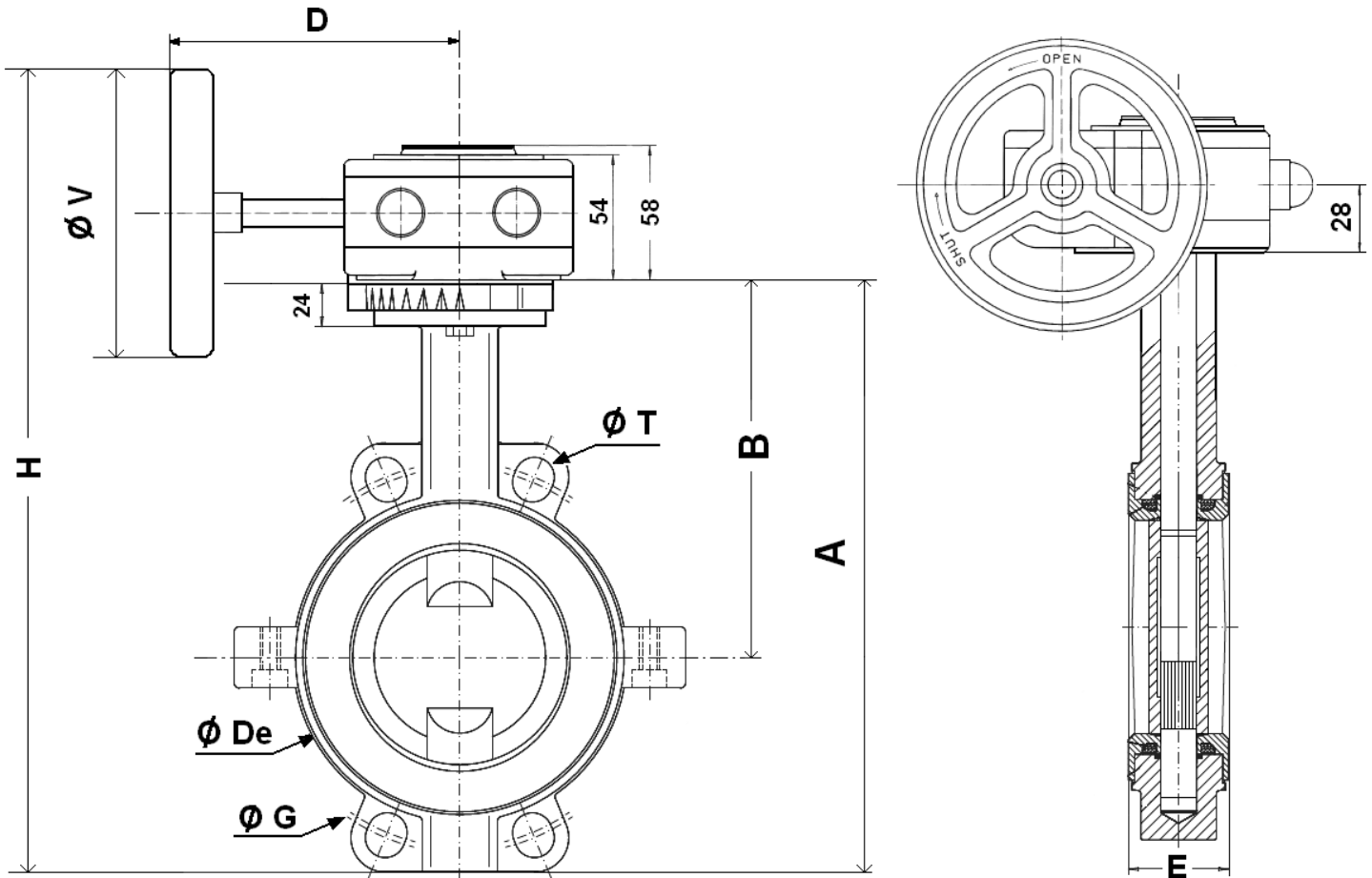

DN	32/40	50	65	80	100	125	150	200	250	300
A	205	228	243	266	294	324	349	438	448	515
B	140	156	162	170	185	207	216	256	248	280
Ø De	83	102	119	135	155	185	208	270	320	373
D	120	120	120	120	120	136	136	136	223	223
E	33	43	46	46	52	56	56	60	68	78
H	304	326	341	364	392	452	477	566	634	701
Ø G	110	125	145	160	180	210	240	295	350	400
Ø T	18	18	18	18	18	18	23	23	23	23
Ø V	140	140	140	140	140	200	200	200	300	300
Weight (Kg)	3.85	5.35	5.92	6.53	7.85	11.25	12.12	18.55	35	46

SIZE ISO PN10 (in mm) :

- **Valves with chain gear box :**

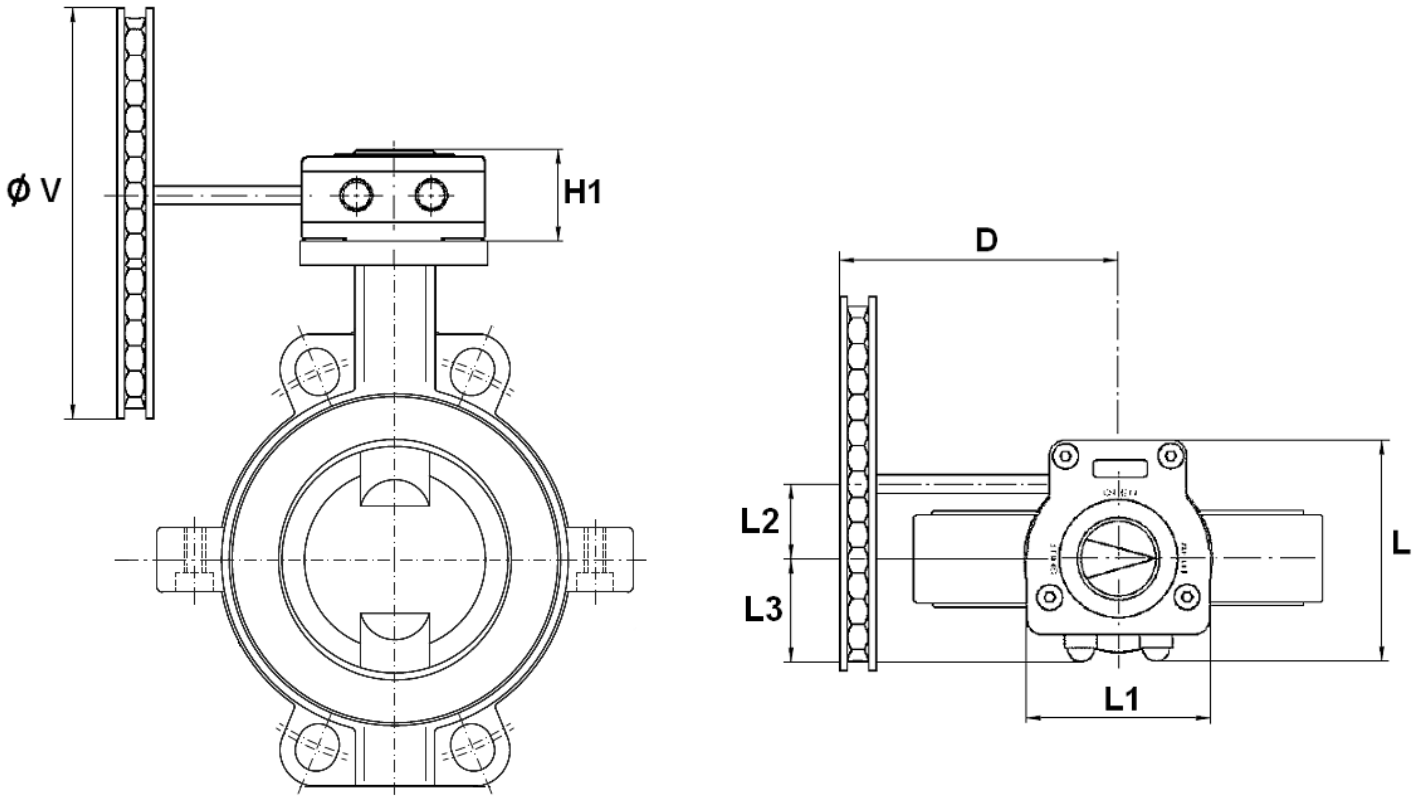

DN	32/40	50	65	80	100	125	150	200	250	300
D	120	120	120	120	120	126	126	126	214	214
H1	58	58	58	58	58	58	58	58	77	77
L	130	130	130	130	130	130	130	130	177.5	177.5
L1	100	100	100	100	100	100	100	100	146	146
L2	50	50	50	50	50	50	50	50	60	60
L3	58	58	58	58	58	58	58	58	82.5	82.5
Ø V	125	125	125	125	125	210	210	200	300	300
Weight (Kg)	4.85	6.35	6.92	7.53	8.85	12.25	13.12	19.55	37.8	48.8

DISC AND NECK SIZE (in mm) :

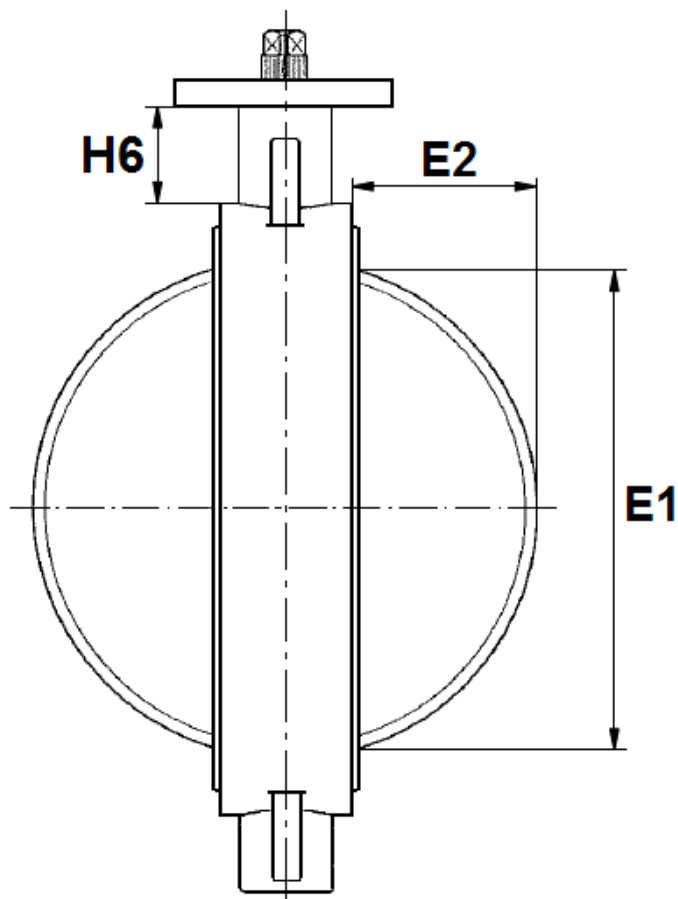

DN	32/40	50	65	80	100	125	150	200	250	300
E1	23	24.5	46	65	85	109	136	188	238	289
E2	3.5	3.5	9.5	17	24	33.5	45.5	69	90	110.5
H6	76	82	80	80	88	93	89	99	71	76

SIZE (in mm) :

- **Stem extension for isolation (75 mm) :**

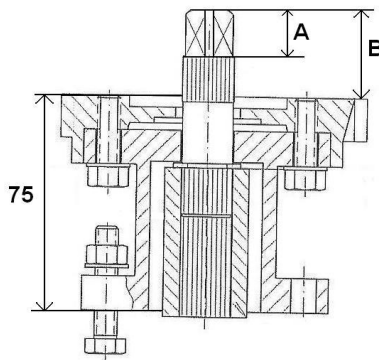

DN	32-50	65	80-100	125-150	200
A	19	19	19	17	17
B	34	34	34	34	34
Weight (Kg)	0.8	0.8	0.9	0.9	1

- **Square lever for special key (30x30 mm) :**

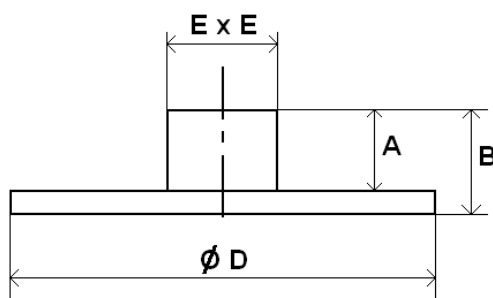

DN	32-50	65	80-100	125-150	200
A	20	20	20	20	20
B	31	31	32	32	32
Ø D	107	107	107	107	107
E x E	30 x 30	30 x 30	30 x 30	30 x 30	30 x 30
Weight (Kg)	0.88	0.88	0.88	0.88	0.88

ISO MOUNTING PAD AND STEM SIZE (in mm) :

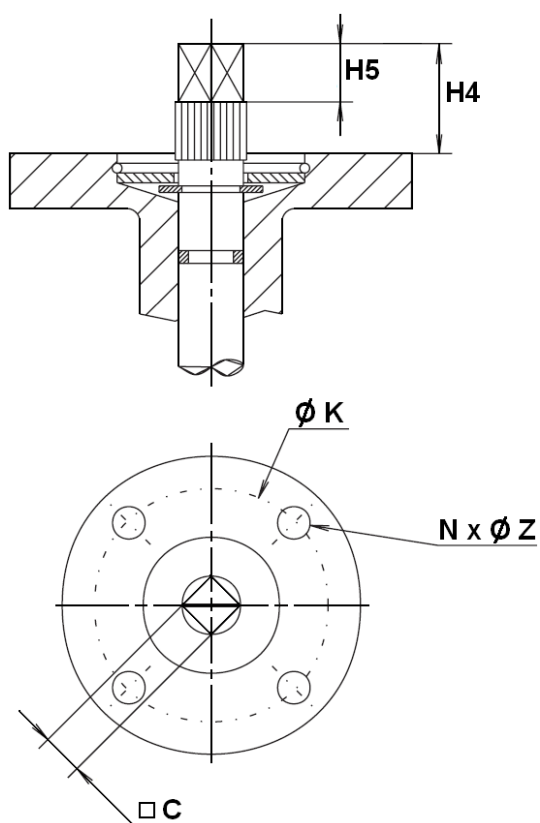

DN	32/40	50	65	80	100	125	150	200	250	300
H4	30	30	30	30	30	30	30	30	40	40
H5	17	17	17	17	17	17	17	17	20	20
C	8	8	9	11	11	14	14	17	19	22
ϕK	70	70	70	70	70	70	70	70	102	102
ISO	F07	F07	F07	F07	F07	F07	F07	F07	F10	F10
$N \times \phi Z$	4 x 9	4 x 9	4 x 9	4 x 9	4 x 9	4 x 9	4 x 9	4 x 9	4 x 11	4 x 11

STANDARDS :

- Fabrication according to ISO 9001:2008
- DIRECTIVE 97/23/CE : CE N° 0038
Risk Category III module H
- Tests according to ISO 5208, A class
- Between flanges according to EN 1092-1 PN10
- ISO 5211 mounting pad
- Length according to ISO 5752 short series 20, EN 558 series 20 (NF 29305),BS 5155 Wafer short/medium, DIN 3202 part 3, series K1
- ATEX Group II Category 2 G/2D Zone 1 & 21 Zone 2 & 22 (optional marking)

INSTALLATION INSTRUCTIONS

GENERAL GUIDELINES :

- Ensure that the valves to be used are appropriate for the conditions of the installation (type of fluid, pressure and temperature).
- Be sure to have enough valves to be able to isolate the sections of piping as well as the appropriate equipment for maintenance and repair.
- Ensure that the valves to be installed are of correct strength to be able to support the capacity of their usage.
- **Installation of all circuits should ensure that their function can be automatically tested on a regular basis (at least two times a year).**

INSTALLATION INSTRUCTIONS :

- **Before installing the valves, clean and remove any objects from the pipes** (in particular bits of sealing and metal) which could obstruct and block the valves.
- **Ensure that both connecting pipes either side of the valve (upstream and downstream) are aligned (if they're not, the valves may not work correctly).**
- **Make sure that the two sections of the pipe (upstream and downstream) match, the valve unit will not absorb any gaps. Any distortions in the pipes may affect the tightness of the connection, the working of the valve and can even cause a rupture.** To be sure, place the kit in position to ensure the assembling will work.

INSTALLATION INSTRUCTIONS (SUITE):

- **If sections of piping do not have their final support in place, they should be temporarily fixed. This is to avoid unnecessary strain on the valve.**
- The valve must be inserted between flanges with disc half opened but the disc must not overpass the valve thickness. Position the bolts to keep centered the valve. Then open fully the valve and tighten the bolts. **See graph under.**

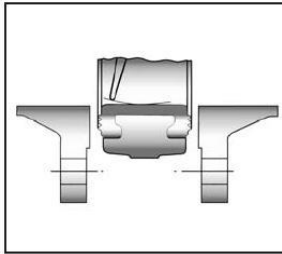

Half open valve introduction

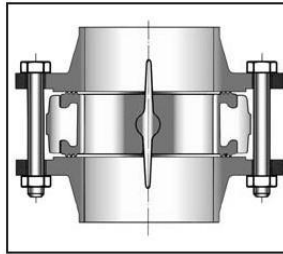

Complete opened disc valves
when screw tightening

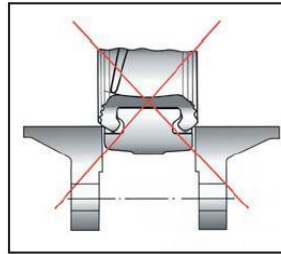

- Tighten the bolts in cross.
- The disc must move easily inside the pipe.
- Valves must be opened during cleaning operation.
- Tests must be done with a cleaned pipe.
- Tests must be done with opened valve. Test pressure must not be higher than the valve specification according to EN 12266-1.
- Then open slowly the valve.
 - **Do not mount butterfly valves with stainless steel pressed collars and turning flanges without strias.**
 - **And not on flat face flanges without strias (example : painted cast iron fittings)**

MAINTENANCE :

- We recommend to operate fully the valve 1 to 2 times per year.
- During maintenance operation, ensure that the pipe isn't under pressure, that there's no fluid in the pipe and that the valve is isolated. If there's a fluid in the pipe , evacuate it. Ensure that there are no risks due to the temperature or the fluid (like acids). If the fluid is corrosive , inert the installation before maintenance operation.