

TYPE	S 38
Nominal pressure/ номинальное давление	PN 16
Nominal size/номинальный размер	DN 40-600

Design / конструкция	EN 1984
Flanges / фланцы	EN 1092-1
Welding end / концы под приварку	EN 12627
Face-to-face/ стр.длина	EN 558-1
Testing/ испытания	EN 12266-1
Pressure/Temperature Давление / температура	EN 12516-1

Operation / управление	
1	Handwheel / маховик
2	Gearbox / редуктор
3	Electric actuator / электропривод

Pos.	Name / Название	Trim		
		1	5	8
4	Wedge facing уплотн.поверх.клина	13 Cr	Stellite 6	13 Cr
6	Seat facing уплотн.поверх. седла	13Cr	Stellite 6	Stellite 6

Pos	Part / деталь	Material / материал			
		-29 - +400 °C	-20 - +593 °C	-47 - +340 °C	-70 - +350 °C
		EN - DIN (ASTM)	EN - DIN (ASTM)	EN - DIN (ASTM)	EN - DIN (ASTM)
1	Body / корпус	GS-C25 (WCB)	GS-17CrMo5-5 (WC6)	GS-20Mn5 (LCB)	GX5CrNi 18-9 (CF8)
2	Yoke / хомут	GS-C25 (WCB)	GS-17CrMo5-5 (WC6)	GS-20Mn5 (LCB)	GX5CrNi 18-9 (CF8)
3	Bonnet / крышка	GS-C25 (WCB)	GS-17CrMo5-5 (WC6)	GS-20Mn5 (LCB)	GX5CrNi 18-9 (CF8)
4	Wedge / клин	GS-C25 (WCB)	GS-17CrMo5-5 (WC6)	GS-20Mn5 (LCB)	GX5CrNi 18-9 (CF8)
5	Stem / пиндель	X15Cr13 (A182 F6)	24CrMoV 5 5 (A182 F11)	X15Cr13 (A182 F6)	X5CrNi 18.10 (F304)
6	Seat / седло	C 22 (A105)+ weld-on	24CrMoV (F11)+weld-on	X15Cr13 (F6)+weld-on	X5CrNi 18.10 (F304)
7	Packing flange / фланец сальника	GS-C25 (WCB)	GS-17CrMo5-5 (WC6)	GS-20Mn5 (LCB)	GX5CrNi 18-9 (CF8)
8	Packing bush / втулка сальника	X15Cr13 (A182 F6)	24CrMoV 5 5 (A182 F11)	TstE 355 (LF2)	X5CrNi 18.10 (F304)
9	Packing / сальник	GRAPHITE	GRAPHITE	GRAPHITE	GRAPHITE
10	Backseat / обратный затвор	X15Cr13 (A182 F6)	24CrMoV 5 5 (A182 F11)	X15Cr13 (A182 F6)	X5CrNi 18.10 (F304)
11	Eye bolt / болт с ушком	42 CrMo4 (A193 B7)	42 CrMo4 (A193 B7)	24 CrMo5 (A182 L7)	42 CrMo4 (A193 B7)
12	Pin / штифт	St 37-2 (A105)	24CrMoV 5 5 (A182 F11)	TstE 355 (LF2)	X5CrNi 18.10 (F304)
13	Nut / гайка	C 45 (A194 2H)	C 45 (A194 2H)	24 CrMo5 (A194 4)	C 45 (A194 2H)
14	Bolt / болт	42 CrMo4 (A193 B7)	42 CrMo4 (A193 B7)	24 CrMo5 (A182 L7)	42 CrMo4 (A193 B7)
15	Stem nut / гайка шпинделя	ZQA19-4 (ZQA19-4)	ZQA19-4 (ZQA19-4)	ZQA19-4 (ZQA19-4)	ZQA19-4 (ZQA19-4)
16	Wheel nut / гайка	C 45 (A194 2H)	C 45 (A194 2H)	C 45 (A194 2H)	C 45 (A194 2H)
17	Hand Wheel / маховик	GGG-40 (A47)	A47 (A47)	GGG-40 (A47)	GGG-40 (A47)
18	Sealing / уплотнение	GRAPHITE	GRAPHITE	GRAPHITE	GRAPHITE

For DN 250 and higher - bonnet and yoke separated, stem nut with bearing / для DN>250 крышка и хомут из отдельных частей, гайка шпинделя в подшипнике

Other material specification upon request / другое исполнение по заказу

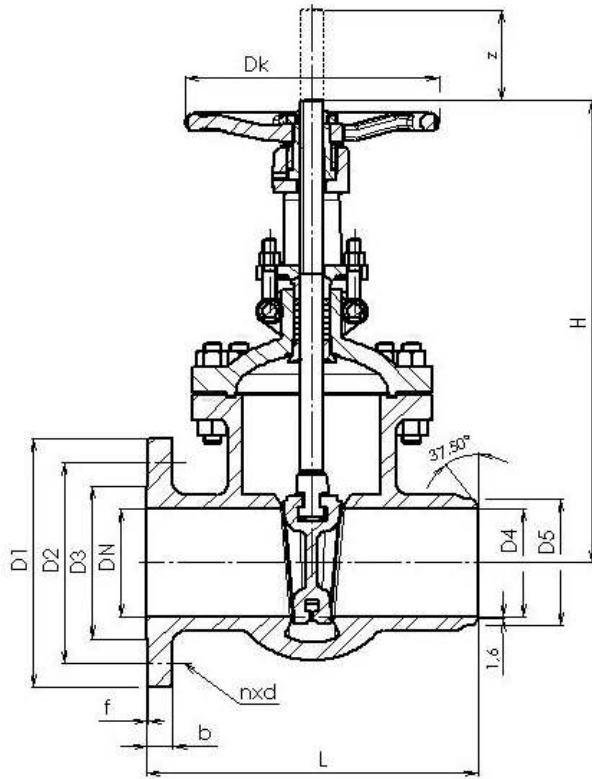

Size/ размер	Torque/ кр.момент	ISO 5210
	PN 16	PN 16
DN40	14 Nm	F10
DN50	16 Nm	F10
DN65	18 Nm	F10
DN80	26 Nm	F10
DN100	40 Nm	F10/F14
DN125	55 Nm	F10/F14
DN150	76 Nm	F10/F14
DN200	120 Nm	F10/F14
DN250	200 Nm	F14
DN300	275 Nm	F14/F16
DN350	345 Nm	F14/F16
DN400	480 Nm	F14/F16
DN500	800 Nm	F14/F16/F25
DN600	1280 Nm	F16/F25

Main and connecting dimensions / главные и присоед. размеры														
DN	40	50	65	80	100	125	150	200	250	300	350	400	500	600
D1	150	165	185	200	220	250	285	340	405	460	520	580	715	840
D2	110	125	145	160	180	210	240	295	355	410	470	525	650	770
D3	88	102	122	138	158	188	212	268	320	378	438	490	610	725
D4	According to pipe dimensions / согласно размеру трубы													
D5	50	62	77	91	117	144	172	223	278	329	362	413	516	629
b	18	18	18	20	20	22	22	24	26	28	30	32	44	54
f	2	2	2	2	2	2	2	2	2	2	2	2	2	2
n	4	4	4*	8	8	8	8	12	12	12	16	16	20	20
d	18	18	18	18	18	18	22	22	26	26	26	30	33	36
Bolt / болт	M16	M16	M16	M16	M16	M16	M20	M20	M24	M24	M24	M27	M30	M33
z	60	72	85	92	117	150	170	225	280	330	365	420	520	625
Dk	200	200	250	250	280	300	300	350	400	450	500	550	650	800
H	350	358	373	435	500	614	674	818	969	1145	1280	1450	2676	2750
L	240	250	270	280	300	325	350	400	450	500	550	600	700	800
m (kg)	16	23	31	37	47	69	93	172	270	341	450	620	973	1360
m weld/ прив.(kg)	12	19	26	32	40	62	83	161	250	310	416	580	880	1265

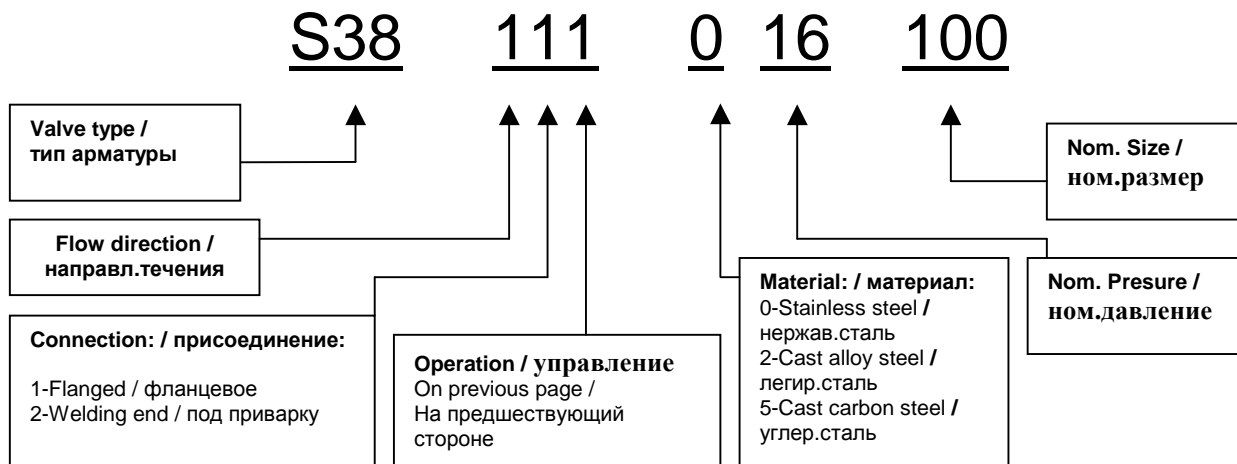

ADDRESS: Armatury Klad s.r.o , Janská 22, 746 01 OPAVA
CONTACT: ☎+ 420 553 621 058, ☎553 624 496, klad@klad.cz , www.klad.cz